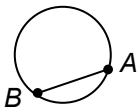
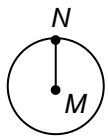
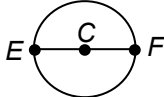
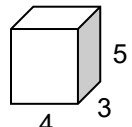

## STUDENT RESOURCES

Word or Phrase	Definition
center of a circle	See <u>circle</u> .
chord	<p>A <u>chord</u> of a circle is a line segment whose endpoints lie on the circle. If the chord passes through the center of the circle, it is a <u>diameter</u> of the circle.</p> <p style="text-align: center;">The segment from <math>A</math> to <math>B</math> is a chord.</p> 
circle	<p>A <u>circle</u> is a closed curve in a plane consisting of all points at a fixed distance (the <u>radius</u>) from a specified point (the <u>center</u>).</p> <p style="text-align: center;">The center is at <math>M</math> and the radius is the length of the line segment from <math>M</math> to <math>N</math>.</p> 
circumference	The <u>circumference</u> of a circle is the length of the circle, that is, the distance around it. The circumference of a circle of radius $r$ is $C = 2\pi r$ . See <u>circle</u> .
diameter	<p>A <u>diameter</u> of a circle is a line segment joining two points of the circle that passes through the center of the circle.</p> <p style="text-align: center;">The line segment from <math>E</math> to <math>F</math> is a diameter.</p> 
pi	<p><u>Pi</u> (written <math>\pi</math>) is the Greek letter used to denote the value of the ratio of the circumference of a circle to its diameter. Pi is an irrational number, with decimal representation</p> <p><math>\pi = 3.14159\dots</math>. The rational numbers 3.14 and <math>\frac{22}{7}</math> are often used to approximate <math>\pi</math>.</p>
radius	A <u>radius</u> of a circle is a line segment from the center of the circle to a point on the circle. The radius of a circle also refers to the length of that line segment. See <u>circle</u> .
surface area	<p>The <u>surface area</u> of a three-dimensional figure is a measure of the size of the surface of the figure, expressed in square units. If the surface of the three-dimensional figure consists of two-dimensional polygons, the surface area is the sum of the areas of the polygons.</p> <p style="text-align: center;">A rectangular box has a length of 3", width of 4", and height of 5".          Surface Area = <math>2(3 \cdot 4) + 2(3 \cdot 5) + 2(4 \cdot 5)</math>  <math>= 94</math> square inches</p> 
volume	<p>The <u>volume</u> of a three-dimensional figure is a measure of the size of the figure, expressed in cubic units.</p> <p style="text-align: center;">A rectangular box has a length of 3", width of 4", and height of 5".          Volume = <math>(3)(4)(5) = 60</math> cubic inches</p>

Summary of Perimeter and Area Formulas			
Shape/Definition	Diagram	Perimeter or Circumference	Area
<p><b>Rectangle</b> a quadrilateral with 4 right angles</p>		$P = 2b + 2h$ or $P = 2l + 2w$	$A = bh$ or $A = lw$
<p><b>Square</b> a rectangle with 4 equal side lengths</p>		$P = 4b$ or $P = 4s$	$A = b^2$ or $A = s^2$
<p><b>Parallelogram</b> a quadrilateral with opposite sides parallel</p>		$P = 2(b + c)$ or $P = 2b + 2c$	$A = bh$
<p><b>Rhombus</b> a quadrilateral with 4 equal side lengths</p>		$P = 4b$	$A = bh$
<p><b>Triangle</b> a polygon with three sides</p>		$P = a + b + c$	$A = \frac{1}{2}bh$
<p><b>Trapezoid</b> a quadrilateral with at least one pair of parallel sides</p>		$P = a + b_1 + b_2 + c$	$A = \frac{1}{2}(b_1 + b_2)h$
<p><b>Circle</b> a closed figure in a plane where all points are a fixed distance (radius) from a given point (center)</p>		$C = 2\pi r$ or $C = \pi d$	$A = \pi r^2$
<p>For consistency, we illustrate all formulas using <math>b</math> to refer to the length of a base. The consistent use of <math>b</math> makes the relationships among formulas more apparent.</p>			

### About Pi

$\pi$  (also written as the Greek letter  $\pi$ ) is the value of the ratio of the circumference of a circle to its diameter. The constant  $\pi$  is slightly greater than 3, so that the circumference of a circle is a little more than 3 times its diameter.

Though we often use 3.14 or  $\frac{22}{7}$  for the value of  $\pi$ , these are only approximations. It can be shown that  $\pi$  is not a rational number. That is, pi cannot be represented as a quotient of two integers. The decimal expansion of pi is nonrepeating (no repeating pattern exists).

$$\pi = 3.1415926535897932384626433832795028841971\dots$$

### Right Prisms

Every right prism has two faces (the Bases) that are congruent parallel polygons, and lateral faces that are rectangles.

Pictured below is a right triangular prism. It has two congruent parallel triangular bases and three faces that are rectangles. It is sitting on one of its lateral faces.

The height of the prism is the distance from one base to the other.

Problem: Find its surface area and volume.

Solution Step 1: Define variables.

Let  $b$  = length of triangular base = 12 cm

Let  $h$  = height of triangular base = 8 cm

Let  $H$  = height of right prism = 14 cm

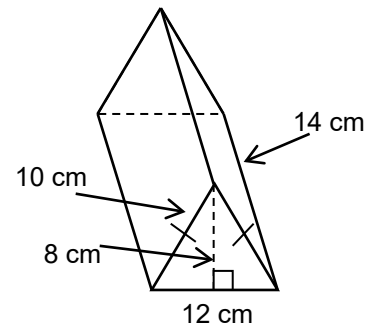

Step 2: Find the volume.

To find the volume ( $V$ ) of any right prism, multiply the area of the base ( $B$ ) by the height ( $H$ ) of the prism.

$$V = BH$$

$$V = \left(\frac{1}{2}bh\right)H$$

$$V = \left(\frac{1}{2} \cdot 12 \cdot 8\right) \cdot 14$$

$$V = (48)(14) = 672 \text{ cm}^3$$

Step 3: Find the surface area.

To find the surface area ( $SA$ ) of any right prism, add the areas of the faces.

Find the area of the triangular base (two of these):

$$A = \frac{1}{2}bh$$

$$A = \frac{1}{2} \cdot 12 \cdot 8 = 48 \text{ cm}^2$$

Find the area of the 10 cm  $\times$  14 cm rectangular face (two of these):

$$A = \ell w = 10 \cdot 14 = 140 \text{ cm}^2$$

Find the area of the 12 cm  $\times$  14 cm rectangular face (one of these):

$$A = \ell w = 12 \cdot 14 = 168 \text{ cm}^2$$

Finally add areas of the faces.

$$SA = 48 + 48 + 140 + 140 + 168$$

$$SA = 544 \text{ cm}^2$$